

Use of Volcanoes for Determination of Direction of Littoral Drift

By

PER BRUUN and GÍSLI VIGGOSSON

The Technical University of Norway

ABSTRACT of paper presented at the 12th International Conference on Coastal Engineering in Washington, D.C. in Sept. 1970.

The title of this paper may sound like a joke. Correctly the title could be "Determination of Direction of Littoral Drift on the South Coast of Iceland by Geomorphological Approach". In order to check the results of such study based on the movements of river entrances and their geometry the use of an accelerometer buoy to be placed in offshore open waters for collection of wave data combined with the results of wave energy calculations based on meteorological data was discussed. Then SURTSEY suddenly emerged from approximately 400 ft depth in Nov. 1964 and its huge outpours of volcanic material built up an "offshore pole station", where the shoreline development during the period when the island had shores of loose material provided some

information which supported the conclusion from the study on the mainland. Computation of wave energy input provided further information which supported the results of the other findings.

The littoral drift on the Icelandic south coast was investigated by means of topographic surveys and aerial photos including:

Survey by the Danish Geodetic Institute, 1906

Survey by the Danish Navy, ab. 1926

Aerial photography, 1945 (Icelandic Survey Dept.)

Aerial photography, 1960 (Icelandic Survey Dept.)

Aerial photography, 1960 U.S. Navy

Aerial photography, July 1963 (Icelandic Dept. of Lighthouses and Ports)

Aerial photography, Aug. 1963 (Icelandic Dept. of Lighthouses and Ports)

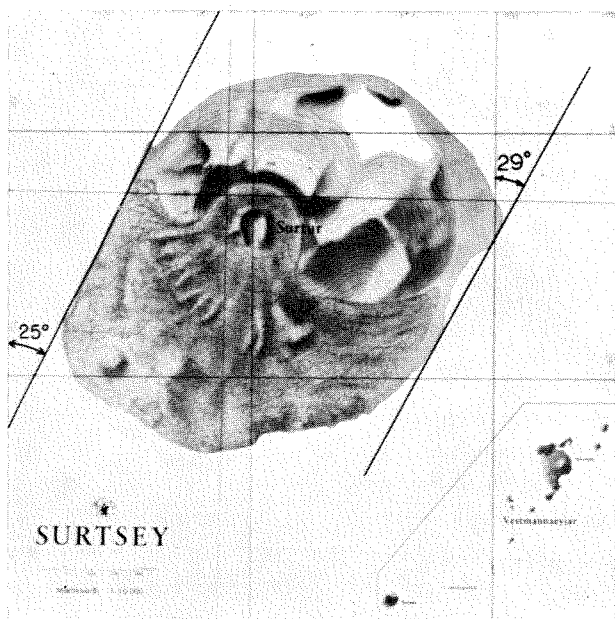

Fig. 2. Surtsey, October 23, 1964.

The results of studies of this material are depicted in Fig. 1, indicating that the predominant littoral drift at Hólsá is eastward, that the drift at the shore between Affall until west of Holtsós is neutral, that the drift from west of Jökulsá and up to Dyrhólaey probably is eastward although some minor outlets demonstrate westward direction which most likely is a seasonal phenomenon. Furthermore that the littoral drift just east of Dyrhólaey is westward. This is in agreement with findings by professor Trausti Einarsson published in article in *Tímarit, Verkfræðingafélag Íslands* (Proceedings of the Icelandic Engineering Association, No. 1–2, 1966, section IV "Radir foksandshóla og forsöguleg stada strandarinnar"). The result was compared to the development of shorelines at Surtsey as studied by Thórarinnsson (Surtsey Research Progress Reports No. II and

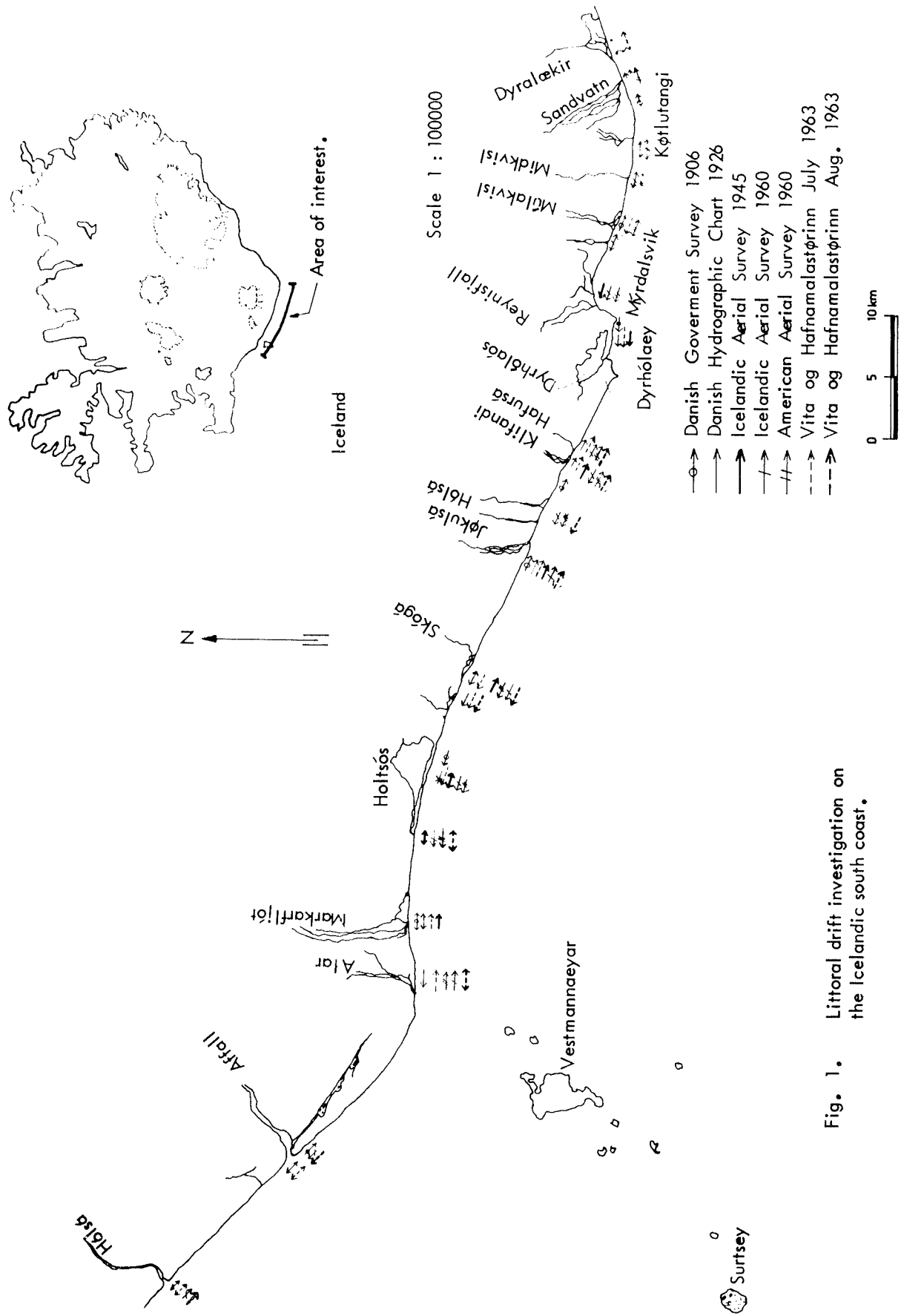

Fig. 1. Littoral drift investigation on the Icelandic south coast.

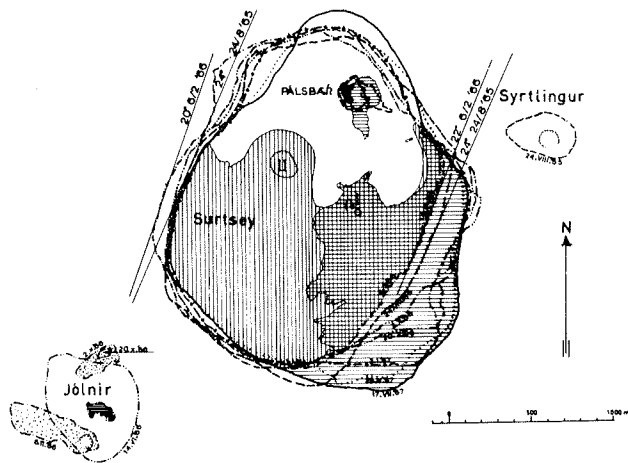

Fig. 3. Outlines of Surtsey during 1965 to 1967.

III 1966 and 1967) and by Norrman (Surtsey Research Progress Report No. IV, 1968).

Figs. 2 and 3 show the development of shorelines at Surtsey during the period from 1964 to 1967 when coarse lava and pebbles normally were available in a narrow beach around the island for long-shore migration by wave action. During extreme storms the solid lava could become exposed, however, in certain sections of the shore. As it may be seen from the figures, the general trend of shorelines development was towards a rectangular shape with rounded corners against SW. The island has two almost parallel sides running SW-NE and an accumulation area on the NE side which developed a lagoon between two beach ridges or barriers growing out from SW, typical for an "angular foreland". The orientation of the two parallel sides is given in the figures. It may be seen that the average orientation of the two parallel sides in 1964 was 27 degrees E of N, which is identical with the orientation of the shoreline west of Dyrhólaey. Next an attempt was made to study the situation by evaluating the wave energy input on the shore in order to find the direction of shoreline with "neutral drift". No wave energy data were available however. The procedures were based on the so-called Los Angeles formula (ref. 1):

$$Q = \frac{1}{2} k_1 w e \sin 2\alpha_b$$

where Q = the total amount of sand moved in littoral drift past a given point per year by waves of given period and direction.

w = total work accomplished by all waves of a given period and direction in deep water during an average year.

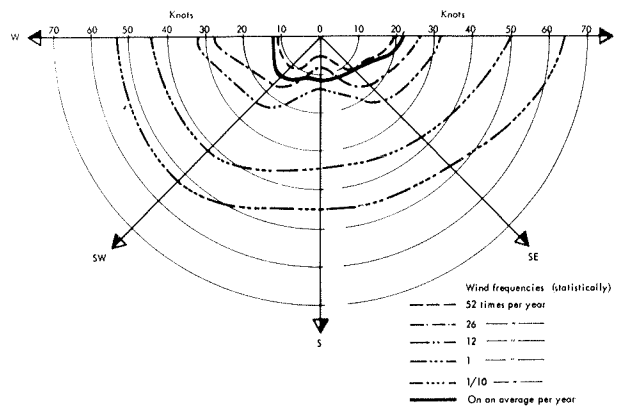

Fig. 4. Wind frequency diagram (offshore) the South Coast of Iceland.

e = wave energy coefficient at the breaker line for waves of a given period and direction. It is the ratio between the distance between orthogonals in deep water and at the shore line.

α_b = angle between wave crests at the breaker line and the shore line, or the angle between orthogonals and the normal to the shore line.

k_1 = factor depending on dimensional units and empirical relations. It varies with beach slope, grain size, and other variables.

The Los Angeles formula may be written as:

$$Q = 6.3 \cdot 10^8 \cdot k_1 H_{1/3}^{2/3} T_{1/3} \cos \alpha_0 \sin \alpha_b$$

ft-lbs/year/ft of crest

where $H_{1/3}$ and $T_{1/3}$ are the significant wave height and period (average of highest one third of all waves and the corresponding average for wave periods). α_0 = deep water angle.

Wind conditions in Iceland are characterized by cyclones moving from SW giving rise to variable wind fields. The average duration of a cyclone moving from SW towards Iceland is 1 to 3 days. The predominant direction of wind wave propagation is towards NE. Because of the fact that no wave data were available it was necessary for a preliminary evaluation to use average wind conditions. Meteorological observations covering a period of 10 years were available. Wind data from three meteorological stations, located in the area between Vestmannaeyjar and Dyrhólaey, were statistically evaluated. Fig. 4 shows frequency diagram. The average wind speed ranged from 12 to 22.5 knots. Hindcasting was based on

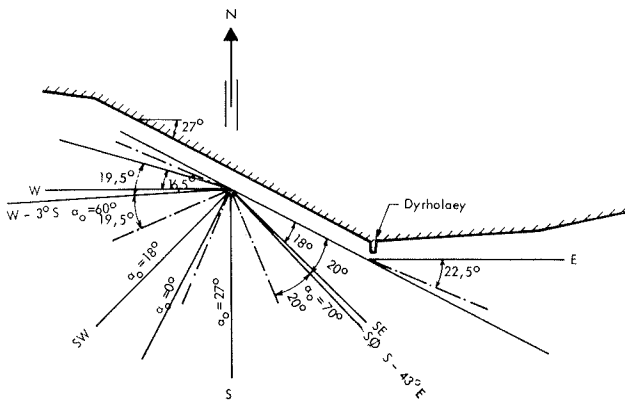

Fig. 5. The shore boundary conditions west of Dyrhólaey.

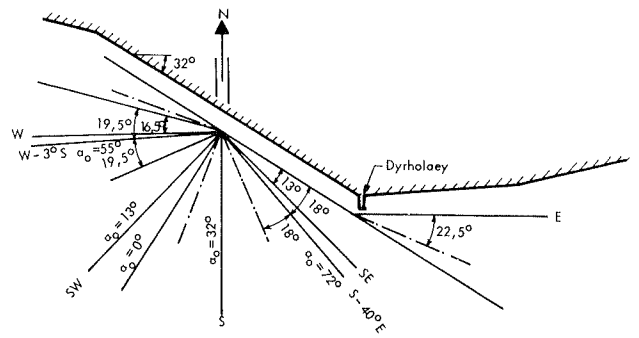

Fig. 6. The shore boundary conditions west of Dyrhólaey when the shore line is turned 5 degrees clockwise.

the SMB (Sverdrup-Munk-Bretschneider) method (ref. 2). The problem here, as usual, is to determine the fetch. A 22.5 knots wind generates a fully developed sea at a fetch of about 135 NM (nautical miles) and a duration of about 14 hours. The wave energy is a function of H^2 and T , and the SMB hindcasting diagrams indicate that wind speeds of 12 to 20 knots have no practical influence on the significant wave height, when the fetch increases from 100 NM to 250 NM. However there is an increase of one second in the significant wave period. For waves generated by the cyclones moving from SW, it is therefore realistic to select a fetch of 250 NM for W and SW. For the other directions a fetch of 135 NM was selected. This agrees with results of Danish investigations on wave action for the harbour of Vestmannaeyjar. The results of hindcasting of deep water energy is shown in Table 1–5 of the article in the Proceedings from the conference in the United States (published by the American Society of Civil Engineers in 1971).

Each wind direction represents a sector of 45 degrees. The actual shore boundary conditions including true shore orientation west of Dyrhólaey are shown in Fig. 5. In Fig. 6 the shoreline was turned 5 degrees clockwise in order to observe the possible influence of this on the drift direction computed on the basis of input of longshore wave energy. The input of energy from E was based on calculation of refraction and diffraction of waves. The results of this investigation was that the shore west of Dyrhólaey has a slight tendency to predominant eastward drift as also indicated by the two previously mentioned approaches. Turning the shoreline 5 degrees clockwise from the actual direction (Fig. 6) changed the resultant energy balance from east-

ward predominance causing westward drift of material.

It was noted that the wave steepness ratio H_0/L_0 (wave height over wave length in deep water) plays an important role for the longshore energy.

The calculations above still refers to the area just west of Dyrhólaey. Further westward the importance of E winds tends to decrease because of the shadow by the Dyrhólaey headland. This in turn would increase tendency to eastward drift. Assuming that this is correct, the shoreline should develop slightly convex (turn clockwise) up towards the Dyrhólaey apart from a small area influenced by leeside erosion just west of the Dyrhólápoint. This is actually the way shoreline configurations has developed. It is therefore evidenced that the orientation of shoreline of ab. 27 degrees N of W is close to the direction which causes neutral drift. The correct average direction may be a few degrees more as is in fact also indicated by the early development of shorelines at Surtsey.

Although none of the methods used are *exact* in the true sense of the word, the similarity of the results are noteworthy. It therefore appears that the development of shorelines of volcanoes popping up from the bottom of the sea, like Surtsey, may be used to determine the direction of littoral drift on nearby shores. As a good luck other methods are available, however. Volcanoes are not always on the spot when needed.

Referance:

- Ref. (1) Bruun, P. (1954), 'Coast Stability', Danish Technical Press, 400 pp, section on 'Equilibrium Forms of Shorelines'.
- Ref. (2) Kinsman B: "Wind Waves their generation and propagation on the ocean surface", Prentice Hall, Inc. Englewood Cliffs. N. J. 1965.